

Square nuts

DIN-557

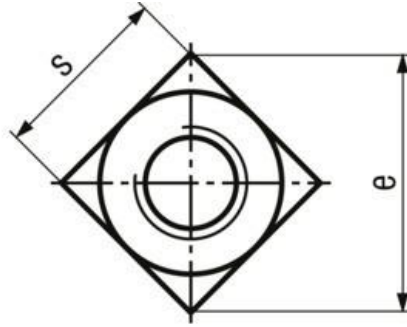
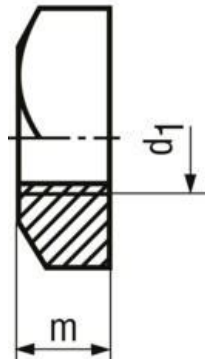

Material

Steel

Strength class

As Per Requirements

Surface

As per Requirement

Standard

DIN-557

M10; M12: wrench size according to ISO on request, M4; M20; M24: not included in DIN 557

Article no.	d1	e~	s	m
5404007	M4	8,6	7	3,2
5405008	M5	11,3	8	4
5406010	M6	14,1	10	5
5408013	M8	18,4	13	6,5
5410017	M10	24	17	8
5412019	M12	26,9	19	10
5416024	M16	33,9	24	13
5420030	M20	37,9	30	16
5424036	M24	45,5	36	19